

SCHMEISER TILL AN' BEDDER

2-BAR AND 4-BAR MODELS
12 FT. TO 20 FT. WIDE

ASSEMBLY & PARTS MANUAL

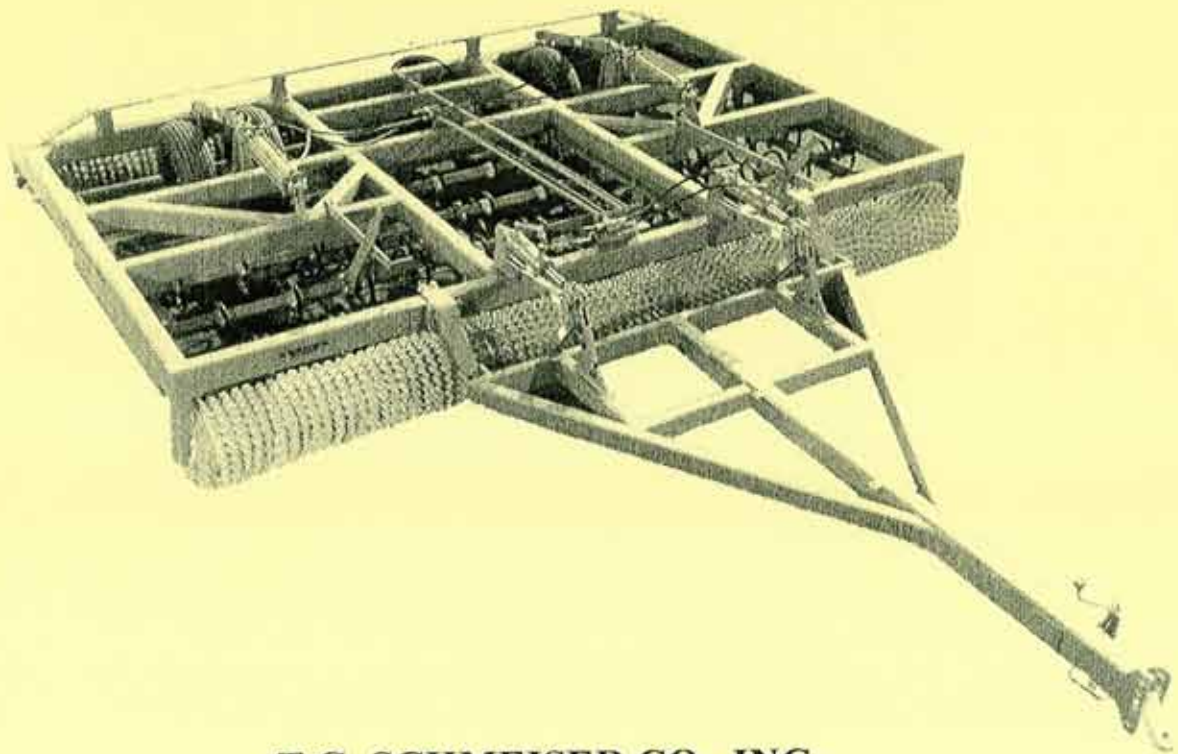

T.G. SCHMEISER CO., INC.
P.O. BOX 1047 FRESNO, CA 93714
(559) 268-8128 FAX (559) 268-3279
www.tgschmeiser.com

VERSION 2.01

FOR UNITS BUILT AFTER MAY 2003

INTRODUCTION

Your Schmeiser Till An' Bedder is designed to give you many years of dependable service. This manual has been prepared to instruct you in the safe and efficient operation of this machine. Read and study it thoroughly. Follow all instructions carefully.

Should your Till An' Bedder require replacement parts, go to your Schmeiser dealer. Always order genuine Schmeiser replacement parts.

It is important that you complete and send in your Warranty Card because it is not valid unless it is on file at Schmeiser. If you need information not contained in this manual, contact your Schmeiser dealer.

Space has been provided below for you to record the model number and serial number of your Till An' Bedder. Be sure to bring this information with you to your dealer when ordering parts or attachments for your Till An' Bedder.

Thank you for buying a Schmeiser Till An' Bedder.

SERIAL NUMBER _____

MODEL NUMBER _____

DATE PURCHASED _____

DEALER NAME _____

TABLE OF CONTENTS

Introduction	1
Table of Contents.....	2
Safety Sheet.....	3
4-Bar Till An' Bedder Assembly.....	4
Assembly Instructions.....	5
2-Bar Till An' Bedder Pull Frame Assembly.....	7
4-Bar Till An' Bedder Pull Frame Assembly.....	8
Till An' Bedder Hitch Assembly.....	9
S-Tine Assembly	10
S-Tine Quantity Tables	11
S-Tine Bar Handle Assembly.....	12
S-Tine Tie Clamp Assembly.....	13
Wheel Axle Bearing Assembly.....	14
Till An' Bedder Wheel Leg Assembly.....	15
Rock Shaft to Main Frame Assembly.....	16
Rock Shaft to Leveling Pipe Frame Assembly.....	17
4 Bar Till An' Bedder Hydraulic Cylinder Configurations	18
Hydraulic Diagram for 2-Bar Till An' Bedder.....	19
Hydraulic Diagram for 4-Bar Till An' Bedder 12' – 14' Units.....	20
Hydraulic Diagram for 4-Bar Till An' Bedder 16' Units.....	21
Hydraulic Diagram for 4-Bar Till An' Bedder 18' – 20' Units.....	22
Limited Warranty.....	23

SAFETY

The safe operation of any machinery is an important concern to farmers and manufactures. There are obvious and hidden potential hazards involved in the operation of this implement. Carefully read and follow all safety precautions before operation. Serious injury or death may occur unless care is taken to insure the safety of both the operator and any other persons in the area.

1. Never permit anyone to ride on or walk beside the implement when moving.
2. Never permit anyone to ride on tractor when implement is being moved.
3. When performing operating functions, never allow anyone to be near the implement or the tractor.
4. Do not enter tractor when tractor is moving. Avoid serious injury or death from contact with rotating tires. Enter and exit the tractor only when it is completely stopped.
5. Be sure of water, gas, sewer, or electric line locations before operating implement.
6. When in transport, use accessory lights and devices for adequate warning to operators of other vehicles. Comply with all Federal, State and local laws when traveling on public roads.
7. Use "Slow Moving Vehicle" emblem for warning vehicles approaching from the rear.
8. When transporting, remember that the implement may be wider than your tractor and extreme care must be taken to allow for safe clearance.
9. Never allow inexperienced or untrained personnel to operate the implement or tractor without supervision.
10. When using compressed air to clean implement, wear safety glasses.
11. Check all fasteners for tightness or damage before and after operation. Repair immediately if required.
12. Store implement in a stable position. Insure that safety stands are extended and locked in place before detaching from tractor.



4-BAR TILL AN' BEDDER ASSEMBLY

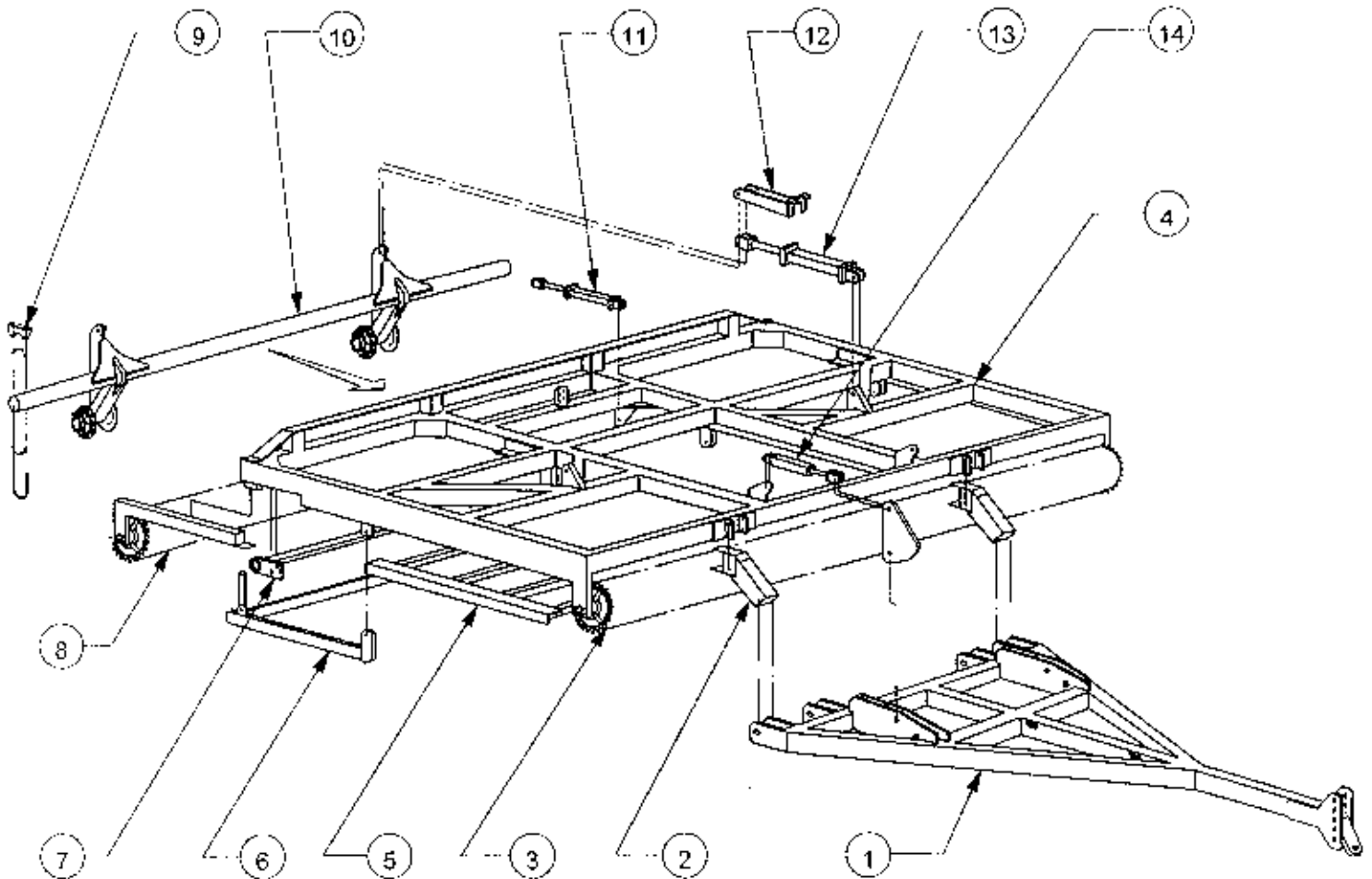

Ref No.	New Part No.	Old Part No.	Description	Qty.
1.	----- *		Pull Frame	1
2.	TBU-00B000		Pull Arm	2
3.	----- *		Front Roller	1
4.	----- *		Main Frame	1
5.	----- *		S-Tine Frame Assembly	1
6.	TBU-00M000		Leveling Pipe Frame	1
7.	----- *		Rock Shaft Assembly	1
8.	----- *		Rear Roller	1
9.	SLL 1353	SLL 1353	Wheel Axle Bearing Assembly	4
10.	----- *		Wheel Axle	1
11.	GHC-25080T	SLL 1301	2.5" x 8" Tie Rod Hydraulic Cyl.	varies **
12.	GWD-420LB1		Lockout Bar for 4" x 20" Hyd. Cyl.	varies **
13.	GHC-40200T	SLL 1309	4" x 20" Tie Rod Hydraulic Cyl.	varies **
14.	GHC-35080W	SLL 1300	3.5" x 8" Welded Hydraulic Cyl.	2

* Part numbers vary depending on width and model number.

** Quantity of cylinders varies. See page 17 for all cylinder configurations.



STEP 1

1. Install Pull Arms (A) as shown
2. Mount Pull Frame (B) to Pull Arms
3. Connect 3-1/2" X 8" Welded Hydraulic Cylinder(s) (C) on to Main Frame (D) and to Pull Frame Pivot Link(s) (E) as shown

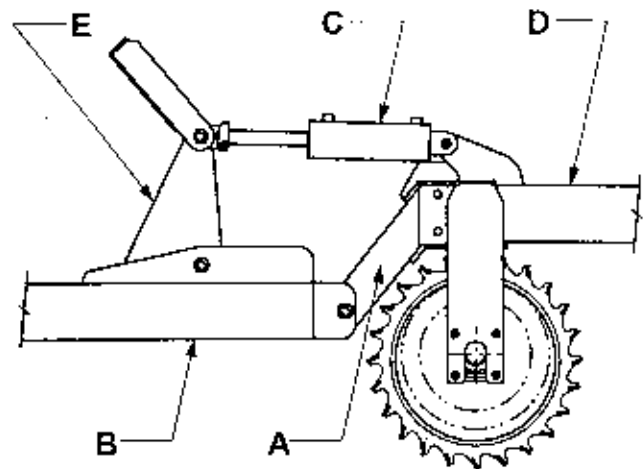

STEP 2

1. Disconnect 4 X 20 Hydraulic Cylinder (F) from Wheel Axle Transport Arm (G)
2. Lift rear of machine approximately 3' to 4'. Support machine securely to prevent falling.
3. Mount Wheels to Transport Axle Hubs (H).
4. Lower machine and reconnect 4 X 20' Hydraulic Cylinder.

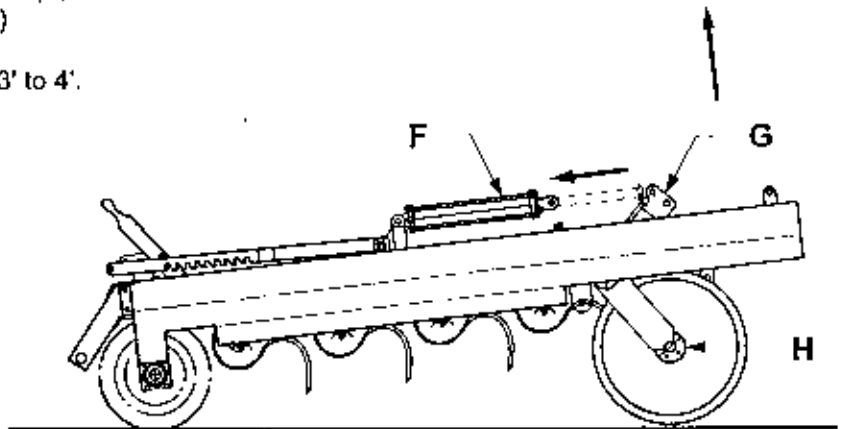

STEP 3 *

1. Mount Rock Shaft (J) to Main Frame (D).
2. Mount Rear Leveling Bar (K) to Main Frame.
3. Mount 2-1/2 X 8 Hydraulic Cylinder (L) to Main Frame and Rock Shaft.

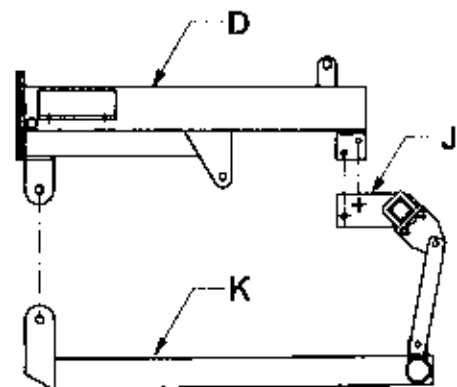
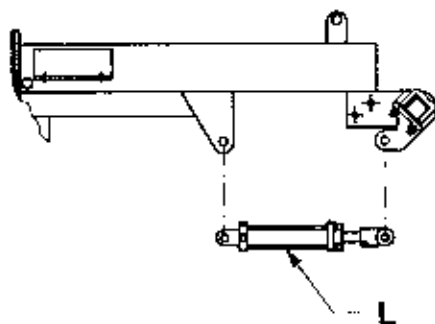

* Refer to pages 15 and 16.



STEP 4

1. Secure Rear Roller Arms (M) to Main Frame (D).
2. Mount Rear Ring Roller Assembly (N) to Rear Roller Arms.
3. Rollers (N) can be mounted for either tilling or packing. When the curved teeth at the rear are pointed upward, the unit is ready for tilling, cultivating and mulching. When the curved teeth point downward, the unit is ready for packing and pulverizing.

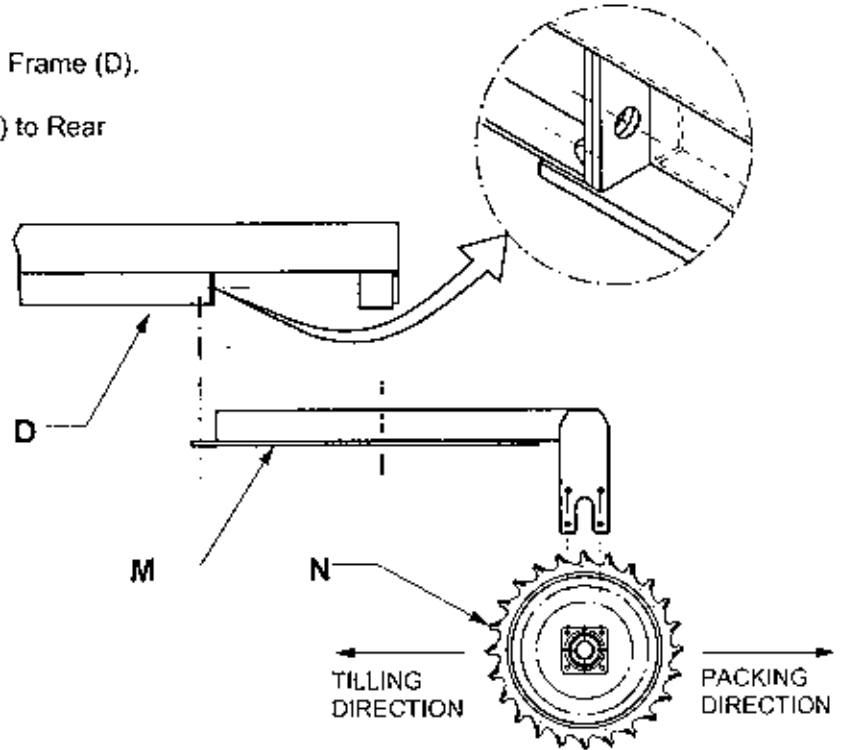

STEP 5

1. Mount Lead Hose Holders (P) to Brackets on Pull Frame *.
2. Insure that all hoses and fasteners are securely connected on Implement.
3. Connect Lead Hoses (not included) to Hydraulic Manifold and Tractor.

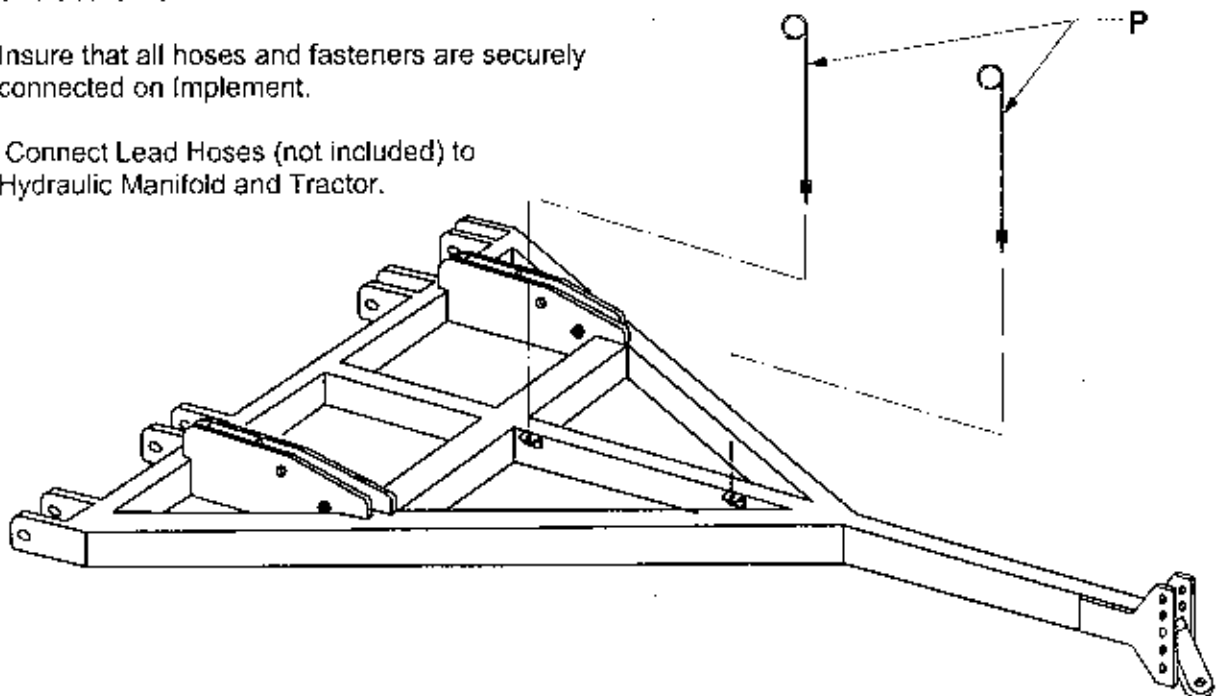

* Two cylinder configuration is shown. See page 17 for all configurations.

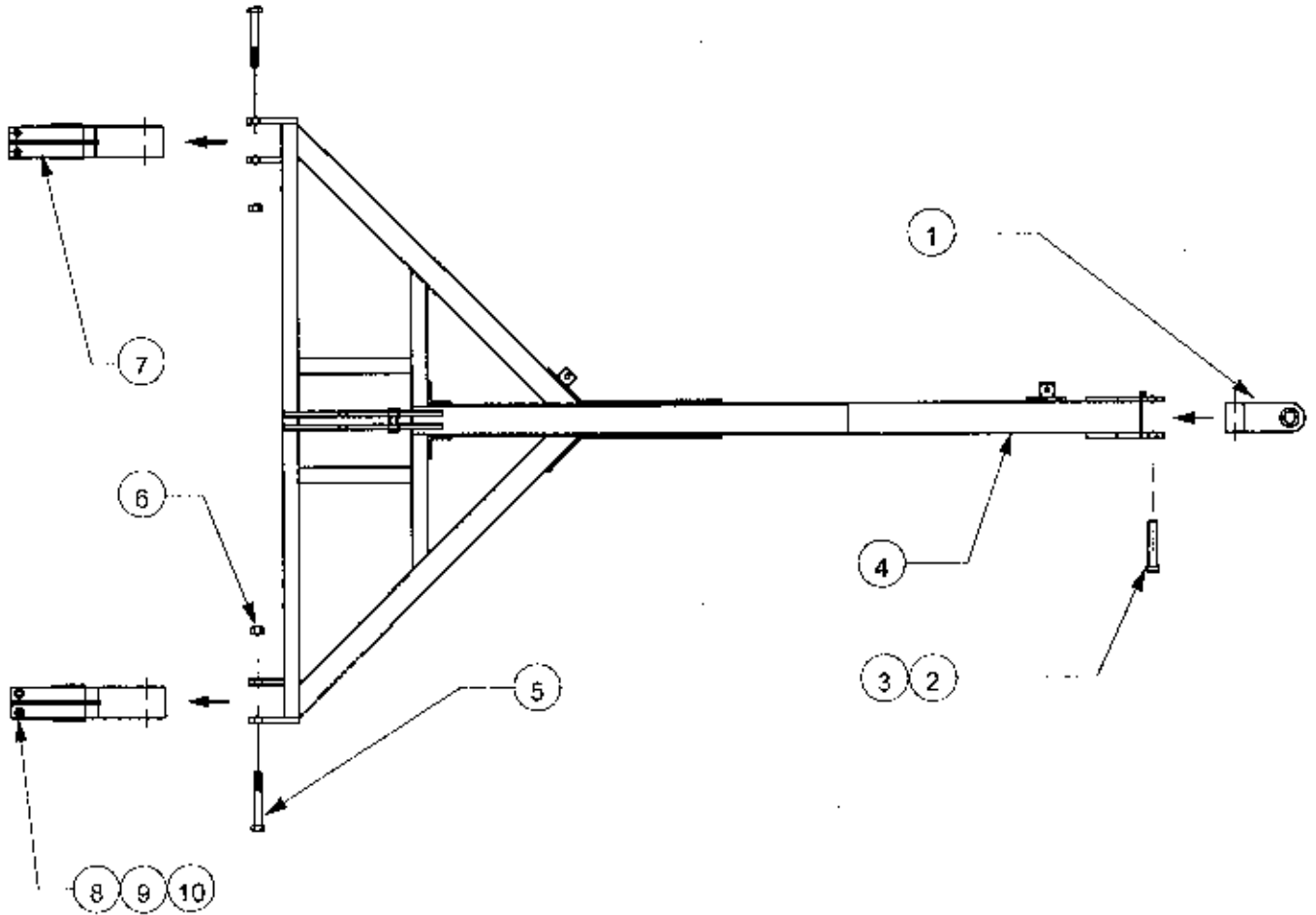

<u>Ref No.</u>	<u>Part No.</u>	<u>Description</u>	<u>Qty.</u>
1.	GWD-150SC1	Clevis Hitch	1
2.	GPN-18A200	1-1/8" X 6" Clevis Hitch Pull Pin	1
3.	GPN-040LYN	1/4" X 3" Lynch Pin	1
4.	TB2-00J100	Pull Frame	1
5.	CSNC516122	1" X 7" NC Cap Screw	2
6.	NYNUT-16NC	1" Nylon NC Hex Nut	2
7.	TBU-00B000	Pull Arm	2
8.	CSNC512112	3/4" X 7" NC Cap Screw	4
9.	HXNUT-12NC	3/4" NC Hex Nut	4
10.	LWASHER-12	3/4" Lock Washer	4



T. G. SCHMEISER CO., INC. **4-BAR TILL AN' BEDDER PULL FRAME ASSEMBLY**

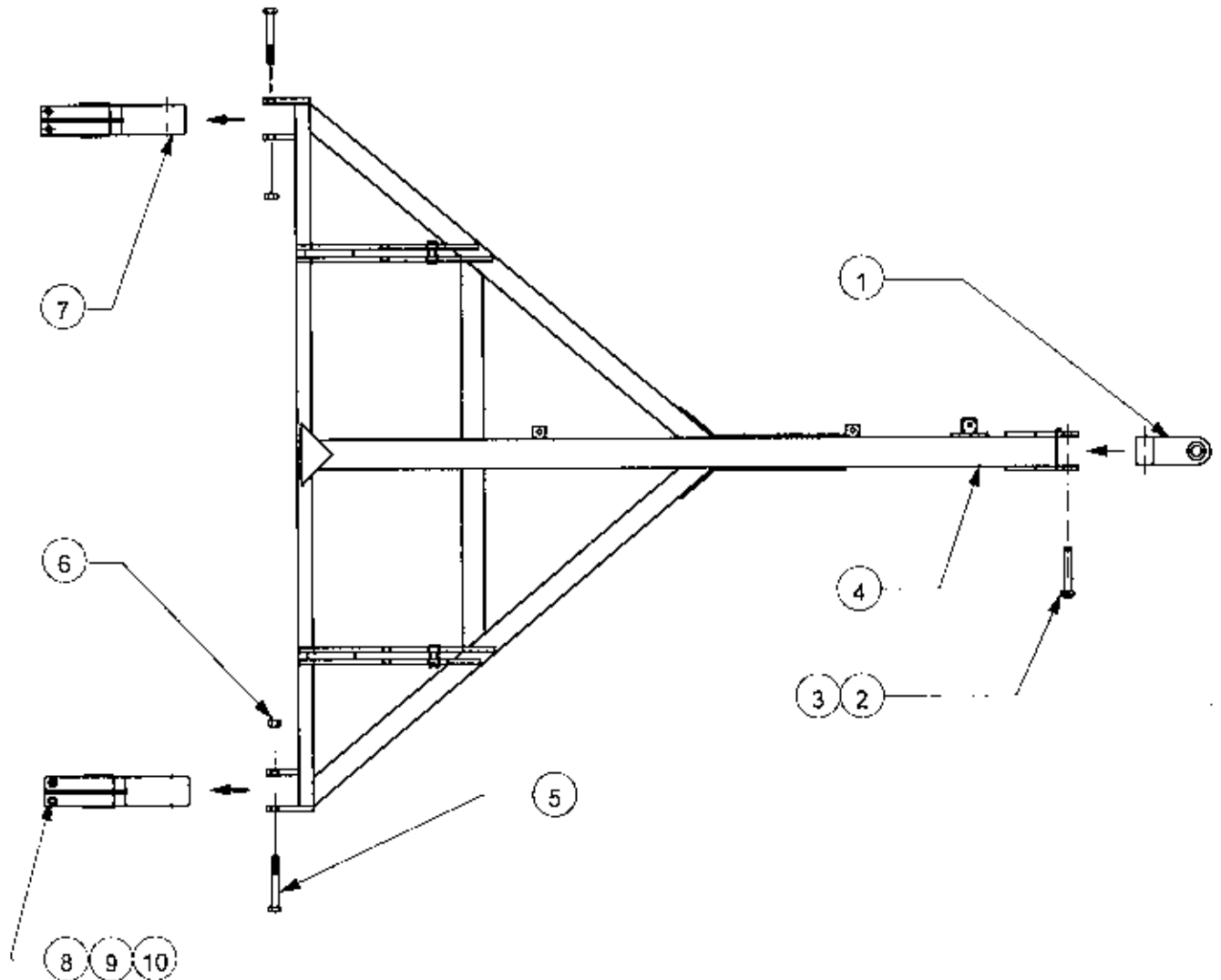

<u>Ref No.</u>	<u>Part No.</u>	<u>Description</u>	<u>Qty.</u>
1.	GWD-150SC1	Clevis Hitch	1
2.	GPN-18A200	1-1/8" X 6" Clevis Hitch Pull Pin	1
3.	GPN-040LYN	1/4" X 3" Lynch Pin	1
4.	TB4-01J100	Pull Frame for 12' and 14' Units	1
	TB4-02J100	Pull Frame for 16', 18', and 20' Units	1
5.	CSNC516122	1" X 7" NC Cap Screw	2
6.	NYNUT-16NC	1" Nylon NC Hex Nut	2
7.	TBU-00B000	Pull Arm	2
8.	CSNC512112	3/4" X 7" NC Cap Screw	4
9.	HXNUT-12NC	3/4" NC Hex Nut	4
10.	LWASHER-12	3/4" Lock Washer	4

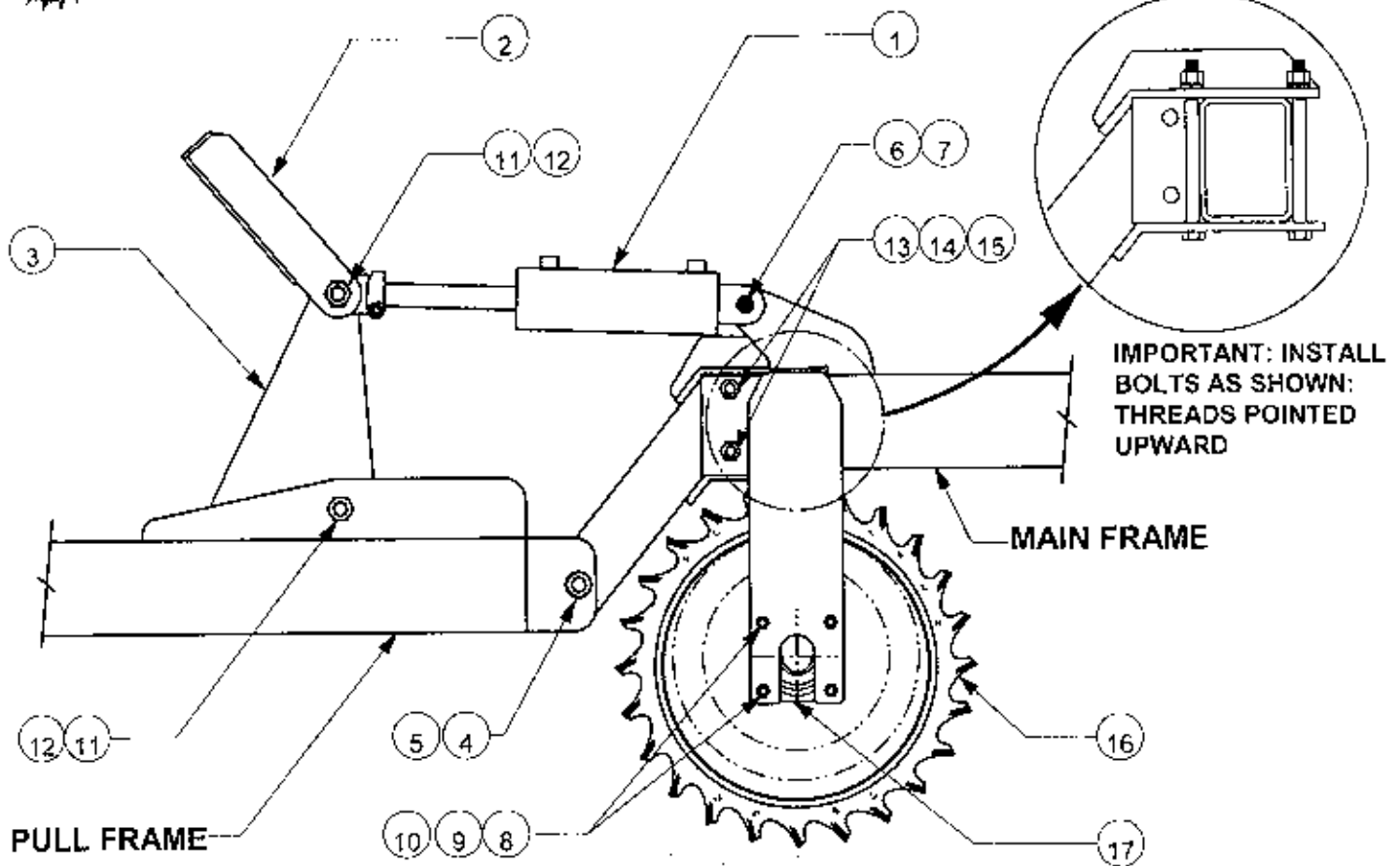

Ref No.	New Part No.	Old Part No.	Description	TB2 Qty.	TB4 Qty.
1.	GHC-35080W	SLL 1300	3.5" X 8" Welded Hydraulic Cyl.	1	2
2.	GWD-358LB1		Lockout Bar For 3.5" X 8" Hydraulic Cyl.	1	2
3.	GPR-L10001	TB4-D	Pivot Plate	1	2
4.	CSNC516122		1" X 7" NC Cap Screw Gr. 5	2	2
5.	NYNUT-16NC		1" NC Nylon Hex Nut	2	2
6.	GPN-16X040		1" X 2-1/2" Clevis Pin	1	2
7.	GPN-04X28C		1/4" X 1-3/4" Cotter Pin	1	2
8.	CSNC508036		1/2" X 2-1/4" NC Cap Screw Gr. 5	8	8
9.	LWASHER-08		1/2" Lock Washer	8	8
10.	HXNUT-08NC		1/2" NC Hex Nut	8	8
11.	CSNC516048		1" X 3" NC Cap Screw Gr. 5	2	4
12.	NYNUT-16NC		1" NC Nylon Hex Nut	2	4
13.	CSNC512122		3/4" X 7" NC Cap Screw	4	4
14.	HXNUT-12NC		3/4" NC Hex Nut	4	4
15.	LWASHER-12		3/4" Lock Washer	4	4
16.	-----		Specify Ring Size	5 /ft	5 /ft
17.	TPP 3152	TPP 3152	1-11/16" Flange Bearing for Units 15' and under *	4	4
	TPP 3157	TPP 3157	1-15/16" Flange Bearing for Units 16' and over *	4	4

* NOTE: Models, fabricated before July 1997, use 1-11/16" and 1-15/16" Pillow Block Bearings.

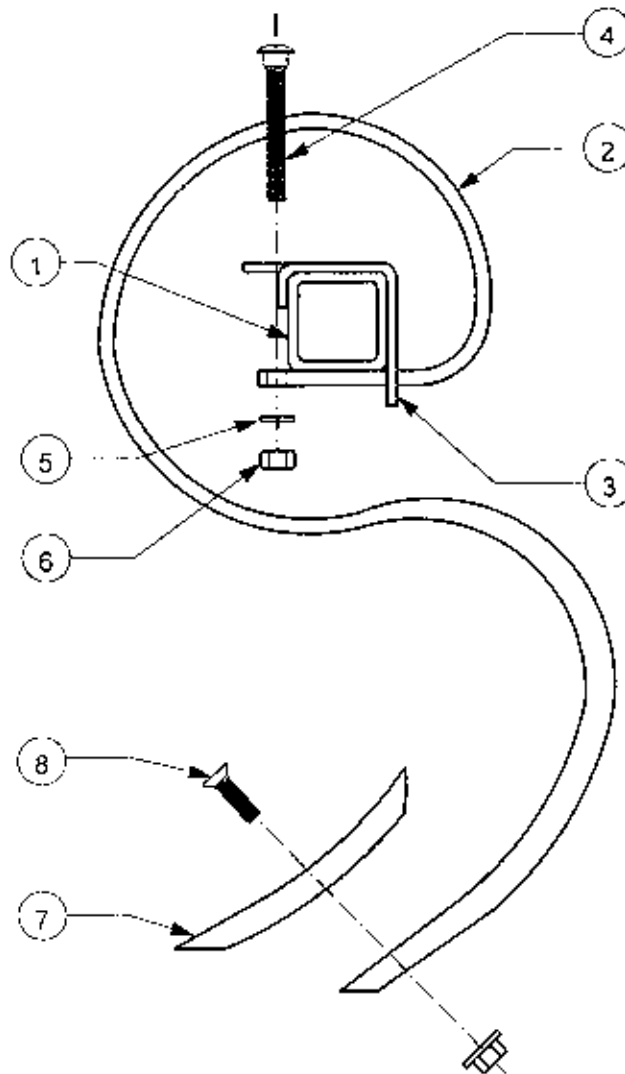

<u>Ref No.</u>	<u>New Part No.</u>	<u>Old Part No.</u>	<u>Description</u>	<u>Qty. *</u>
1.	TBU-00K101		2-1/2" X 2-1/2" S-Tine Bar (specify length)	varies
2.	GST-50125S	SBM 2550A	1/2" X 1-1/4" S-Tine	varies
3.	GST-2CL250		2-1/2" Tool Bar Clamp	varies
4.	CBNC508064		1/2" X 4" Round Head Square Neck Bolt	varies
5.	LWASHER-08		1/2" Lock Washer	varies
6.	HXNUT-08NC		1/2" NC Hex Nut	varies
7.	GST-25150P	SBM 2551	1/4" Standard S-Tine Point	varies
8.	GST-0624BN	SBM 2552	3/8" X 1-1/2" Elliptical Head Metric Plow Bolt w/Nut	varies
9.	SBM 2553	SBM 2553	S-Tine Bar Clamp Assembly (includes items 3, 4, 5, and 6)	varies

* See table on page 11

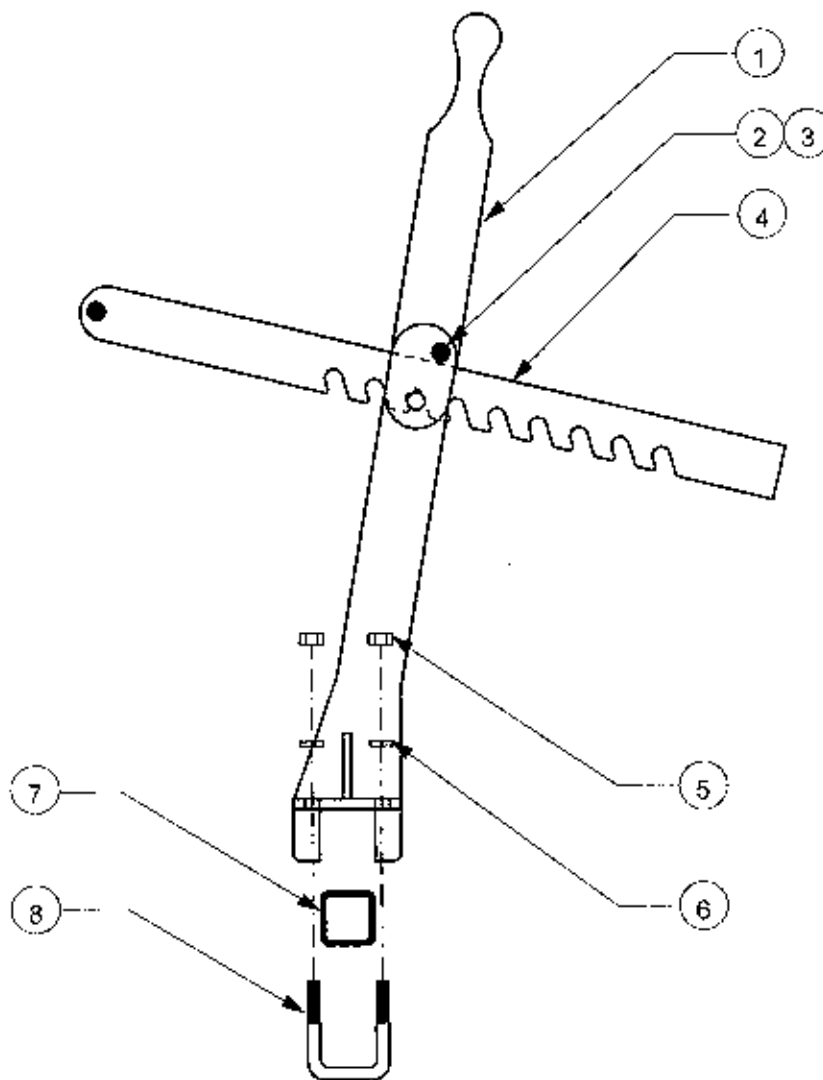

TABLE FOR 2-BAR TILL AN' BEDDER

Ref. #	Part Number	Description	Qty.				
			12'	14'	16'	18'	20'
1.	TBU-00K101	2-1/2" X 2-1/2" S-Tine Bar	2	2	2	2	2
2.	GST-25150S	1/4" X 1-1/2" S-Tine	25	29	33	35	39
3.	GST-2CL250	2-1/2" Tool Bar Clamp	25	29	33	35	39
4.	CBNC508064	1/2" X 4" Round Head Square Neck Bolt	25	29	33	35	39
5.	LWASHER-08	1/2" Lock Washer	25	29	33	35	39
6.	HXNUT-08NC	1/2" NC Hex Nut	25	29	33	35	39
7.	GST-25150P	1/4" Standard S-Tine Point	25	29	33	35	39
8.	GST-0624BN	3/8" X 1-1/2" Elliptical Head Metric Plow Bolt w/Nut	25	29	33	35	39

TABLE FOR 4-BAR TILL AN' BEDDER

Ref. #	Part Number	Description	Qty.				
			12'	14'	16'	18'	20'
1.	TBU-00K101	2-1/2" X 2-1/2" S-Tine Bar	4	4	4	4	4
2.	GST-25150S	1/4" X 1-1/2" S-Tine	34	40	49	54	60
3.	GST-2CL250	2-1/2" Tool Bar Clamp	34	40	49	54	60
4.	CBNC508064	1/2" X 4" Round Head Square Neck Bolt	34	40	49	54	60
5.	LWASHER-08	1/2" Lock Washer	34	40	49	54	60
6.	HXNUT-08NC	1/2" NC Hex Nut	34	40	49	54	60
7.	GST-25150P	1/4" Standard S-Tine Point	34	40	49	54	60
8.	GST-0624BN	3/8" X 1-1/2" Elliptical Head Metric Plow Bolt w/Nut	34	40	49	54	60



Ref No.	Part No.	Description	TB2 Qty.	TB4 Qty.
1.	TBU-00K500	S-Tine Bar Handle	1	2
2.	GPN-12X040	3/4" X 2-1/2" Clevis Pin	1	2
3.	GPN-04X28C	1/4" X 1-3/4" Cotter Pin	1	2
4.	TB2-00K800	TB2 Front S-Tine Adjustment Lockout Arm	1	-
	TB4-00K600	TB4 Front S-Tine Adjustment Lockout Arm - Small	-	1
	TB4-00K700	TB4 Rear S-Tine Adjustment Lockout Arm - Large	-	1
5.	HXNUT-10NC	5/8" NC Hex Nut	2	4
6.	LWASHER-10	5/8" Lock Washer	2	4
7.	TBU-00K101	2-1/2" X 2-1/2" S-Tine Bar	2	4
8.	UBNC10X41S	5/8" X 11" Square Bend U-bolt	1	2

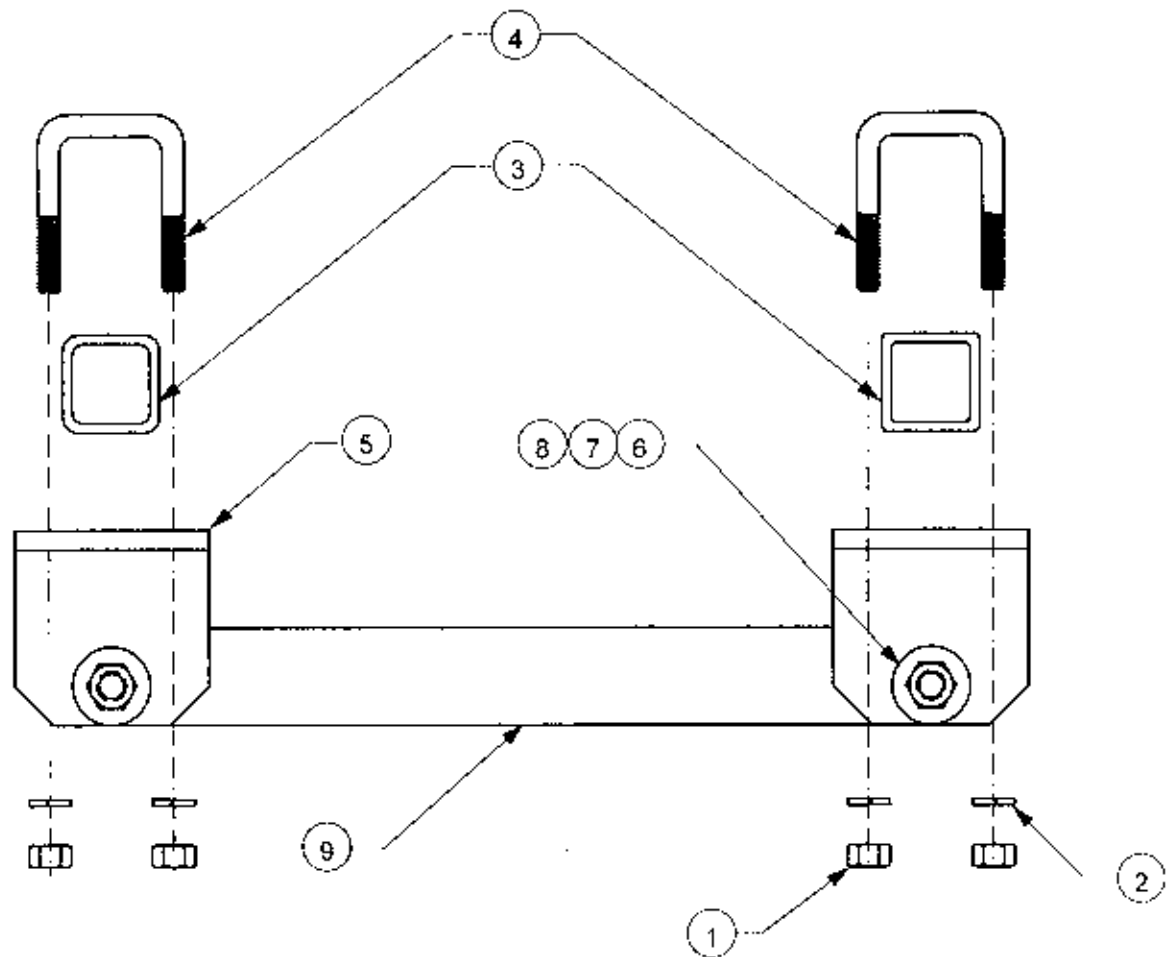

Ref No.	Part No.	Description	TB2 12'-16'	TB2 18'-20'	TB4 12'-16'	TB4 18'-20'
1.	HXNUT-10NC	5/8" NC Hex Nut	8	16	16	32
2.	LWASHER-10	5/8" Lock Washer	8	16	16	32
3.	TBU-00K101	2-1/2" S-Tine Bar (specify length)	2	2	4	4
4.	UBNC10X41S	5/8" X 11" Sq. Bend U-bolt	4	8	8	16
5.	GPR-A50003	S-Tine Tie Clamp Bracket	4	8	8	16
6.	CSNC512040	3/4" X 2-1/2" NC Cap Screw Gr. 5	4	8	8	16
7.	FWASHER-12	3/4" Flat Washer	8	16	16	32
8.	NYNUT-12NC	3/4" NC Nylon Hex Nut	4	8	8	16
9.	GPR-F50004	S-Tine Tie Bar for 2-Bar Unit	2	4	-	-
	TB4-00K402	S-Tine Tie Bar for 4-Bar Unit	-	-	4	8

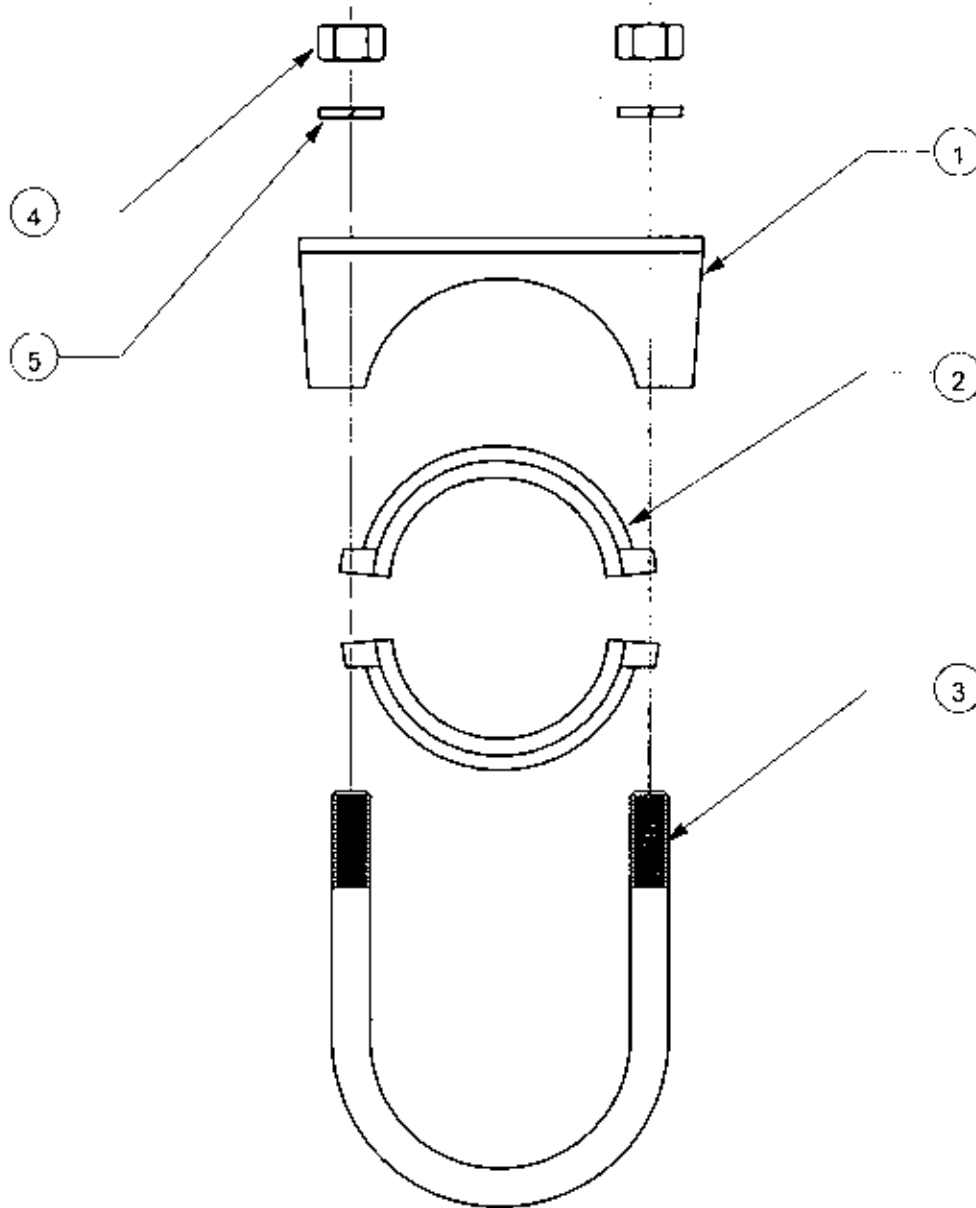

<u>Ref No.</u>	<u>New Part No.</u>	<u>Old Part No.</u>	<u>Description</u>	<u>Qty.</u>
1.	SLL 1351	SLL 1351	Bearing Cradle Cap Weldment	4
2.	SLL 1350	SLL 1350	Bearing Cap Casting Machined	8
3.	UBNF16122U		1" Bearing U-bolt	4
4.	HXNUT-16NC		1" NC Hex Nut	8
5.	LWASHER-16		1" Lock Washer	8
6.	SLL 1352	SLL 1352	U-Bolt Assembly (includes items 3, 4, and 5)	4
7.	SLL 1353	SLL 1353	Wheel Bearing Assembly (includes items 1, 2, 3, 4, and 5)	4



TILL AN' BEDDER WHEEL LEG ASSEMBLY

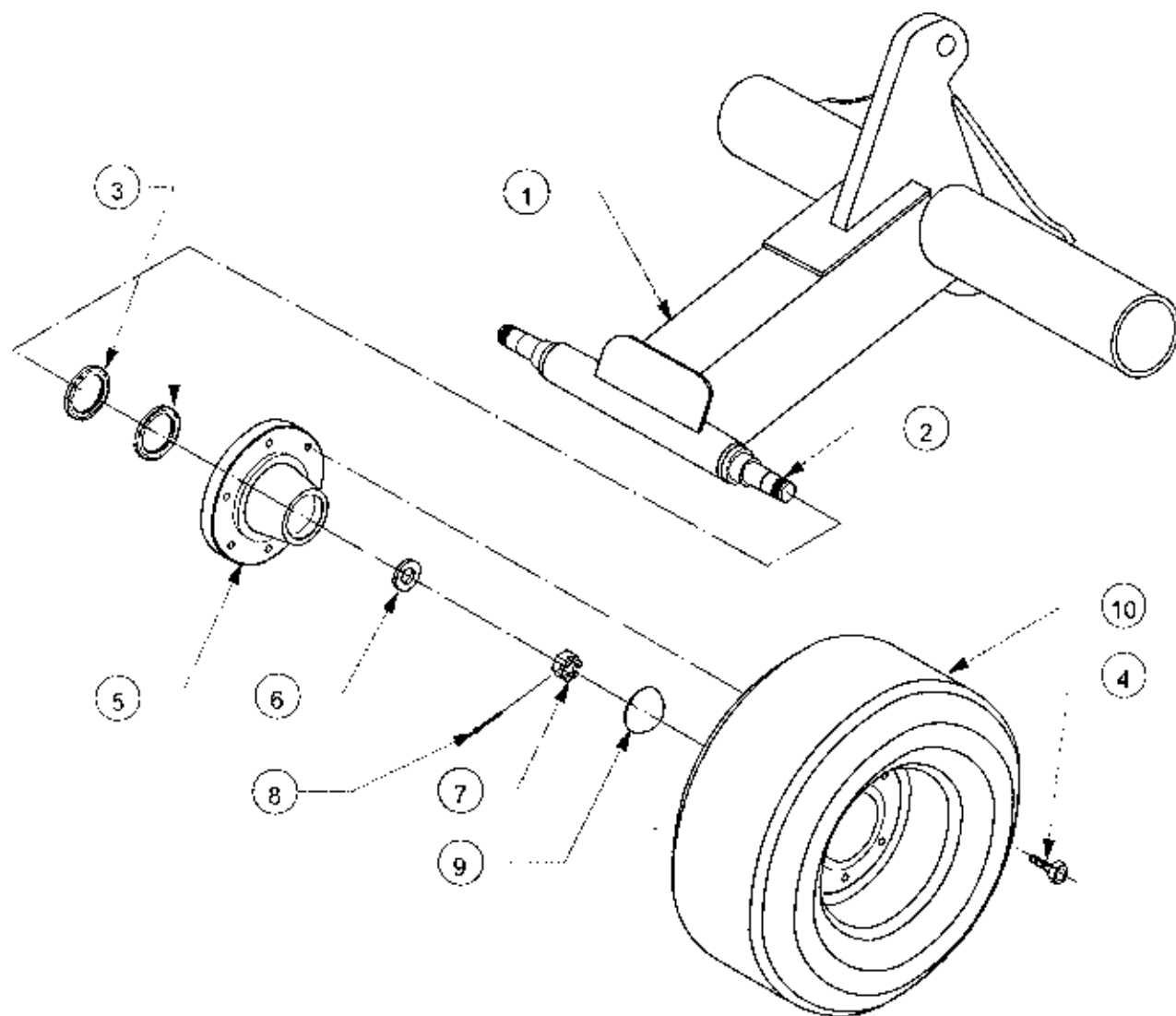

<u>Ref No.</u>	<u>Part No.</u>	<u>Description</u>	<u>Qty.</u>
1.	TBU-01G000	Wheel Leg Weldment for TB2 and TB4 12' to 14' Units	1
	TB4-02G000	Wheel Leg Weldment for TB4 16', 18' and 20' Units	1
2.	GSP-32324D	2" x 20-1/4" Double Ended Spindle for 12'-14' Units	2
	GSP-32372D	2" x 23-1/4" Double Ended Spindle for 16'-20' Units	2
3.	GHB-6X6GSL	Grease Seal	2
4.	WHB-08X016	1/2" x 1" UNF Wheel Bolts for 6 on 6 Std. Hub	2
5.	GHB-6X6STD	Standard 6 on 6 Hub Assembly Complete	1
6.	GSP-14SPWA	Spindle Washer	1
7.	GSP-14CANT	Spindle Castle Nut	1
8.	GPN-03X032C	3/16" x 2" Colter Pin	4
9.	GHB-6X6CAP	Hub Cap	---
10.	GWT-156LBH	15 X 6 Wheel - Standard	2
	GWT-761508	7.6 x 15 8 Ply Tire with Wheel - Optional	2

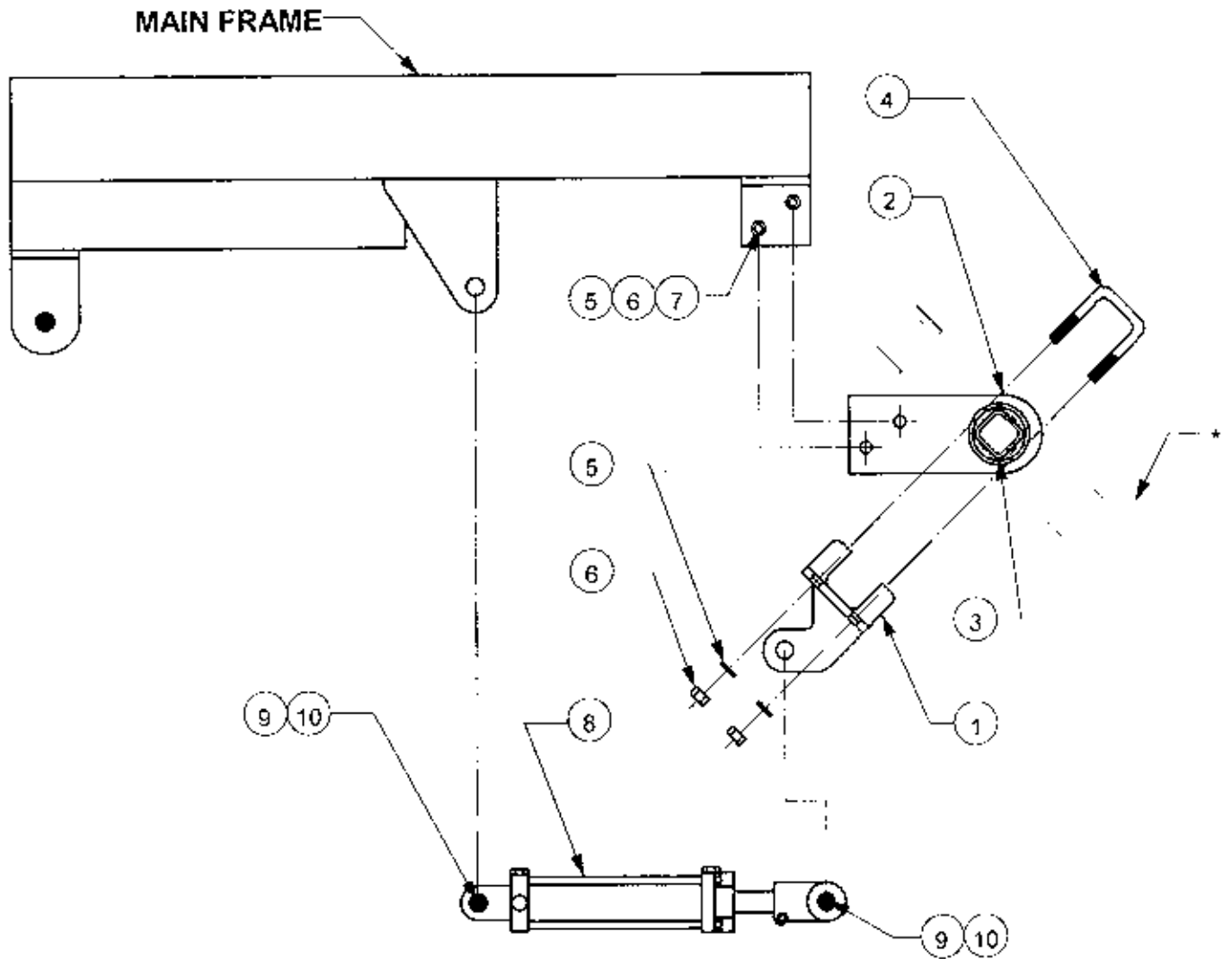

* Note orientation of Cylinder Anchor (1) in relation to Clevis Plates (*).

Ref No.	New Part No.	Old Part No.	Description	TB2	TB4 12'-16'	TB4 18'-20'
1.	GWD-03LA00		Hydraulic Cylinder Anchor Weld.	1	1	2
2.	GWD-01LA00		Rock Shaft Bracket Weldment	4	4	4
3.	TBU-00L100		2-1/2" Main Tube (specify length)	1	1	1
4.	UBNC10X41S	TB4-L7	5/8" X 11" Square Bend U-bolt	1	1	2
5.	LWASHER-10		5/8" Lock Washer	6	6	8
6.	HXNUT-10NC		5/8" Standard NC Hex Nut	6	6	8
7.	CSNC510032		5/8" X 2" NC Cap Screw	8	8	8
8.	GHC-25080T	SLL 1301	2.5" X 8" Tie Rod Hydraulic Cyl.	1	1	2
9.	GPN-16X048		1" X 3" Clevis Pin	2	2	4
10.	GPN-04X28C		1/4" X 1-3/4" Cotter Pin	2	2	4

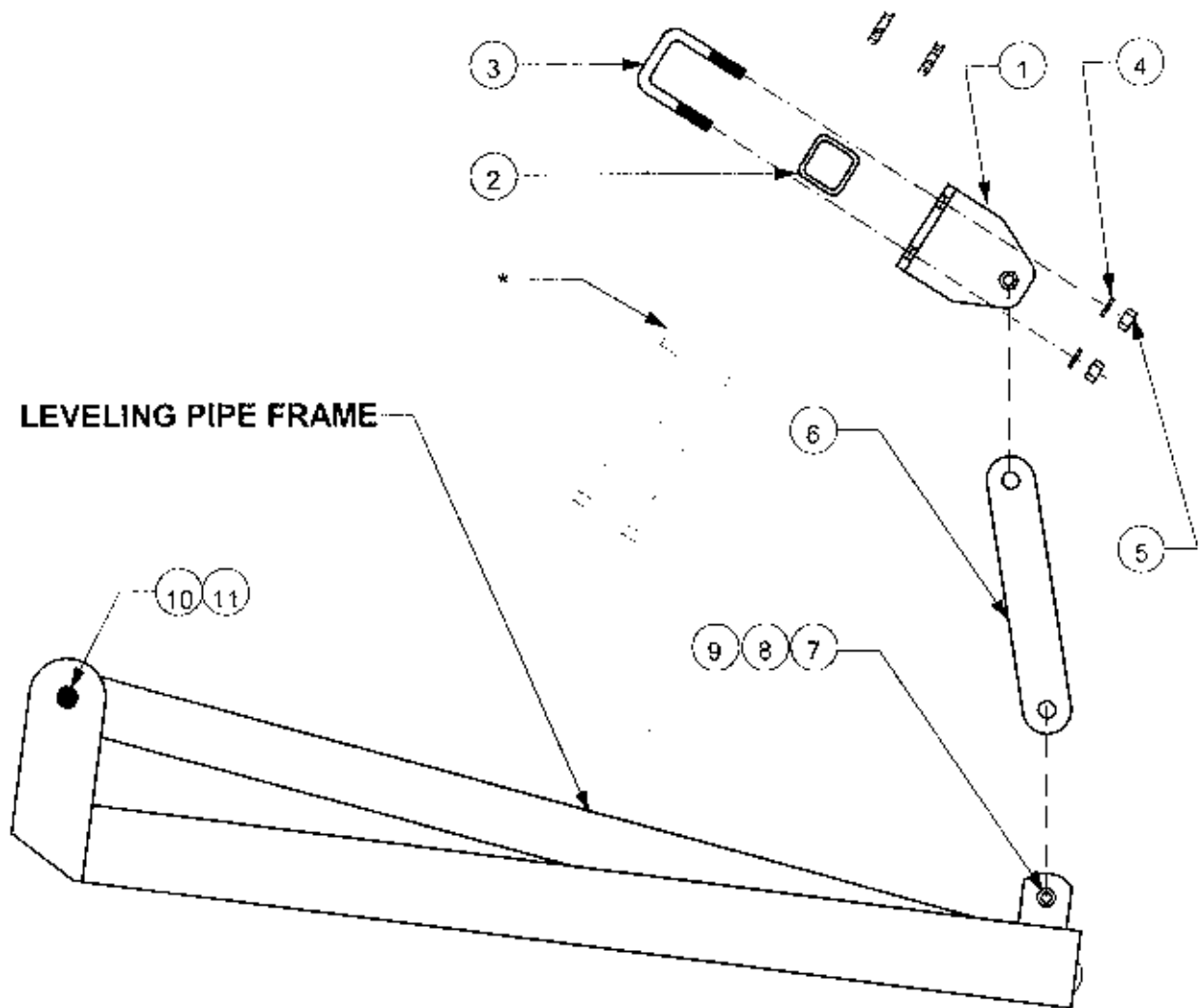

* Note orientation of Cylinder Anchor (*) in relation to Clevis Plates (1).

<u>Ref No.</u>	<u>Part No.</u>	<u>Description</u>	<u>Qty.</u>
1.	TBU-00L300	Linkage Clevis Plates Weldment	4
2.	TBU-(00)L100	2-1/2" Main Tube (specify length)	1
3.	UBNC10X41S	5/8" X 11" Square Bend U-bolt	4
4.	LWASHER-10	5/8" Lock Washer	8
5.	HXNUT-10NC	5/8" Standard NC Hex Nut	8
6.	GPR-L05004	Leveling Bar Link	4
7.	CSNC512040	3/4" X 2-1/2" NC Cap Screw	4
8.	FWASHER-12	3/4" Flat Washer	4
9.	NYNUT-12NC	3/4" NC Nylon Hex Nut	4
10.	GPN-16X040	1" X 2-1/2" Clevis Pin	4
11.	GPN-040LYN	1/4" X 3" Lynch Pin	4

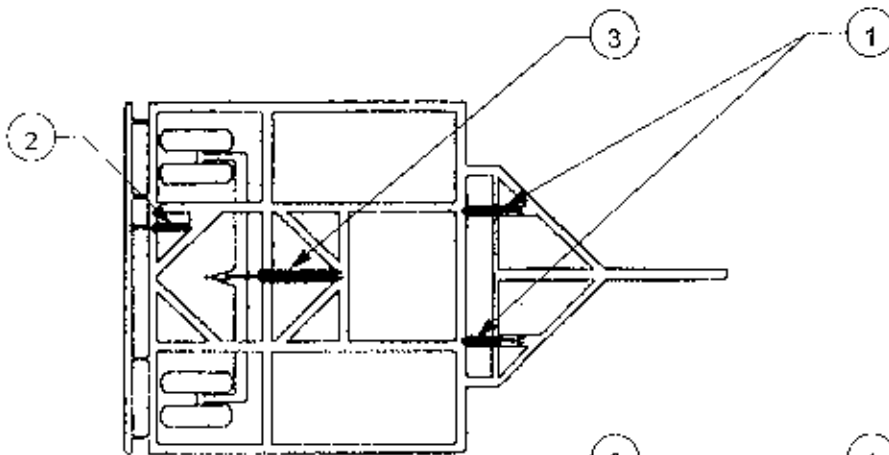

12' AND 14' UNITS

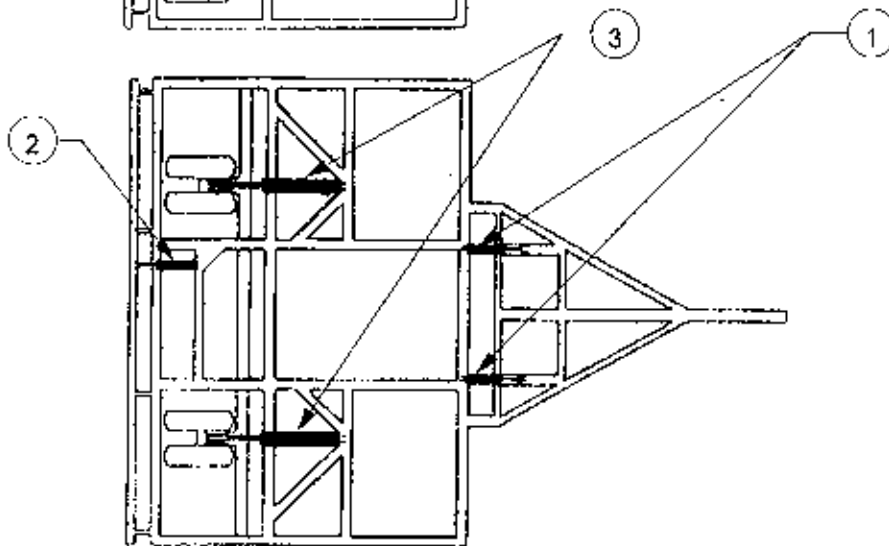

16' UNITS

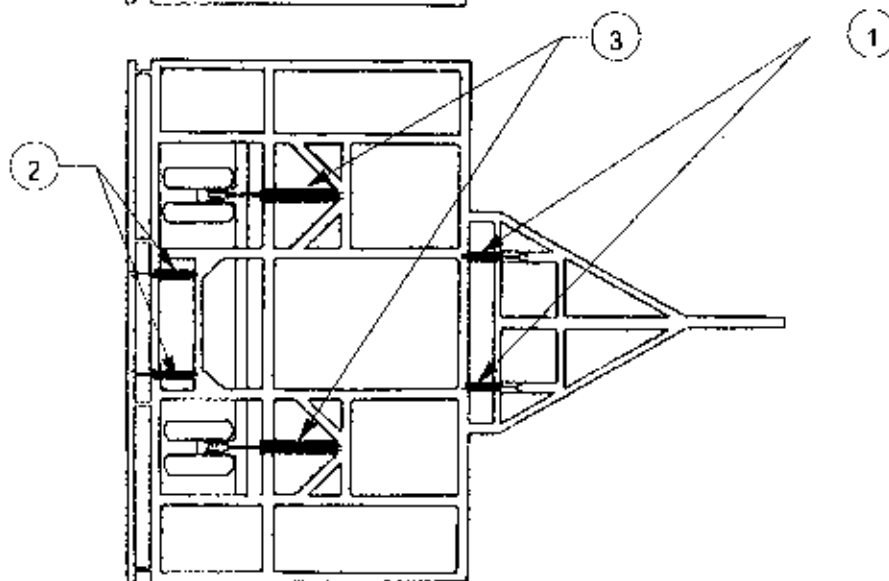

18' AND 20' UNITS

Ref No.	Old Part No.	New Part No.	Description	Qty.
1.	SLL 1300	GHC-35080W	3.5" X 8" Welded Hydraulic Cylinder	2
2.	SLL 1301	GHC-25080T	2.5" X 8" Tie Rod Hydraulic Cylinder	1 or 2
3.	SLL 1309	GHC-40200T	4" X 20" Tie Rod Hydraulic Cylinder	1 or 2



T. G. SCHMEISER CO., INC. **2-BAR TILL AN' BEDDER HYDRAULIC DIAGRAM**

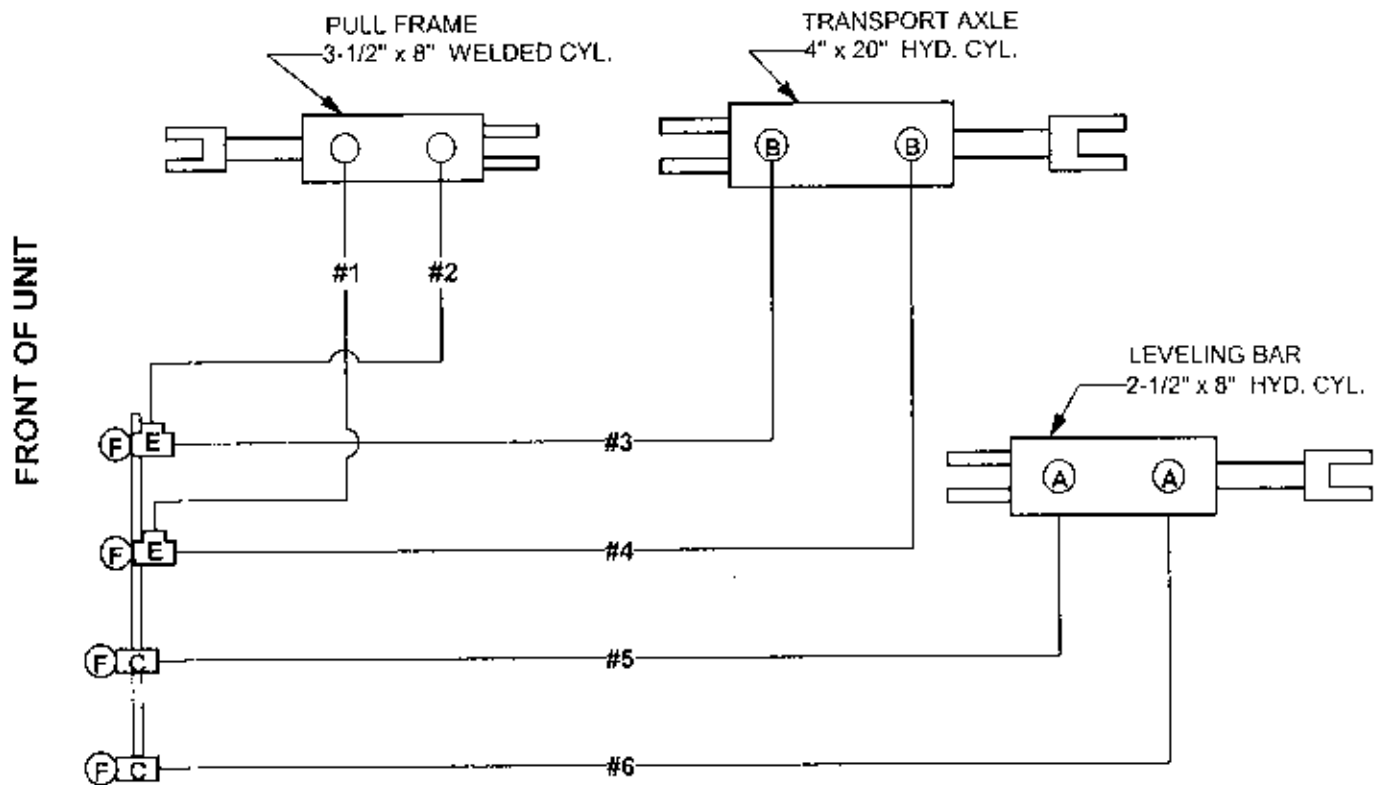

NOTE: Typical for all 2-Bar Till An' Bedder models.

FITTINGS (ALL FITTINGS ARE 3000#)

- A. (2) MB-FP-8-8 COUPLING
- B. (2) MB-FPX90-8-8
- C. (2) FP-FP-8-8 COUPLING
- E. (2) FPT-8
- F. (4) MP-8 PLUGS

HOSES (ALL HOSES ARE 1/2" Ø)

- #1. (1) 8MP-8MPX 34" LONG
- #2. (1) 8MP-8MPX 27" LONG
- #3. (1) 8MP-8MP 27" LONG
- #4. (1) 8MP-8MP 40" LONG
- #5. (1) 8MP-8MPX 88" LONG
- #6. (1) 8MP-8MPX 98" LONG

HYDRAULIC CYLINDERS

- (1) 2-1/2" x 8" Tie Rod Cylinder
- (1) 3-1/2" x 8" Welded Cylinder
- (1) 4" x 20" Tie Rod Cylinder

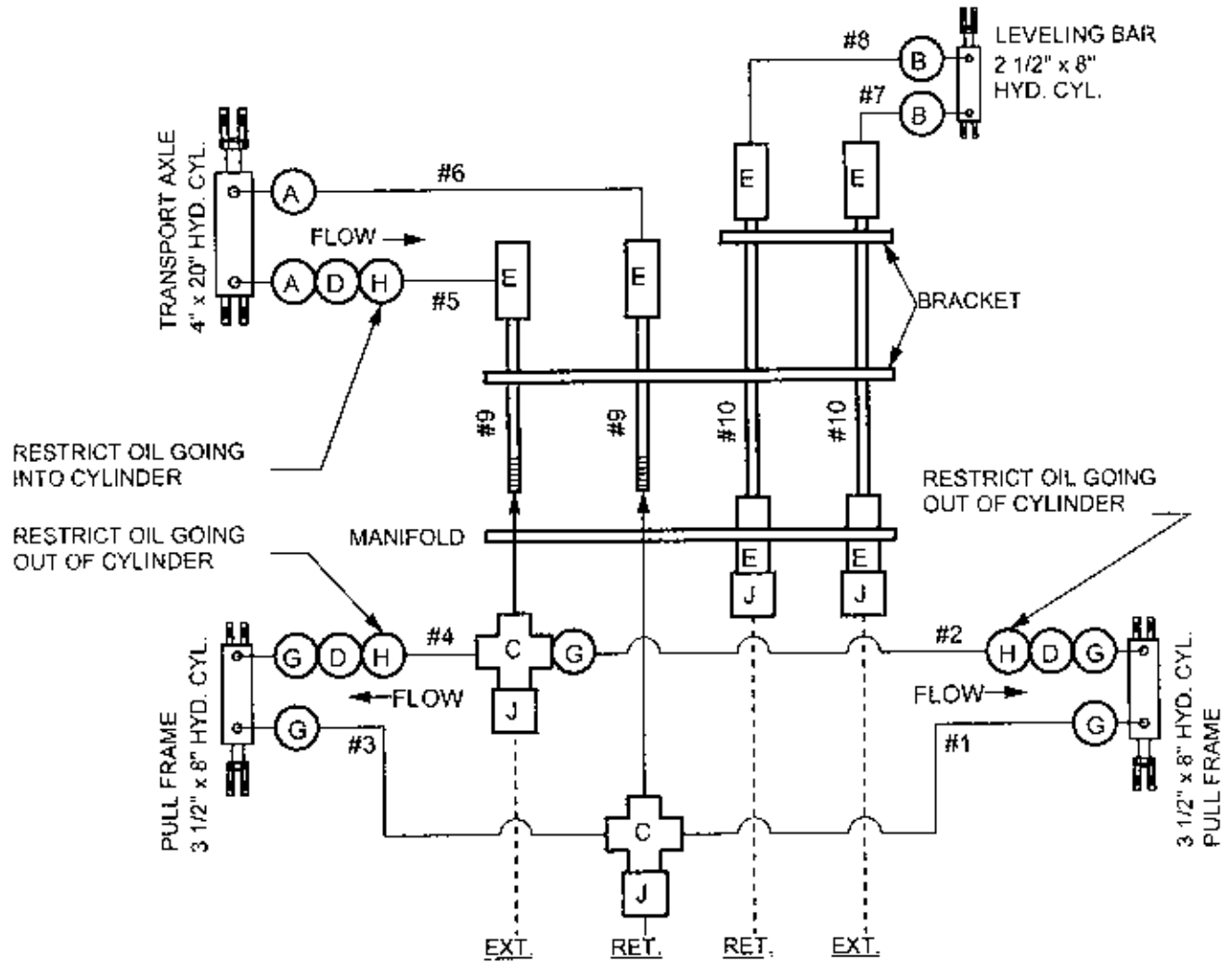

FRONT OF UNIT

FITTINGS:

- A. (2) 8MB-8FPX90°
- B. (2) 8MB-8FP STGHT LINK
- C. (2) 8FP CROSS FITTING
- D. (3) 8MP NIPPLES
- E. (6) 8FP COUPLINGS
- G. (5) 8MP-8FPX90°
- H. (3) PM-R-13 RESTRICTORS
W/ 3/32" Ø HOLE
- J. (4) 8MP PLUGS

NOTE: ALL FITTINGS 3000# CAP.

HYD. CYLINDERS

- (1) 2 1/2" x 8" TIE ROD CYL.
- (2) 3 1/2" x 8" WELDED CYL.
- (1) 4" x 20" TIE ROD CYL.

HOSES:

- #1 - (1) 8MP-8MP 24" LONG
- #2 - (1) 8MP-8MP 20" LONG
- #3 - (1) 8MP-8MP 48" LONG
- #4 - (1) 8MP-8MP 43" LONG
- #5 - (1) 8MP-8MP 18" LONG
- #6 - (1) 8MP-8MP 32" LONG
- #7 - (1) 8MP-8MPX 40" LONG
- #8 - (1) 8MP-8MPX 46" LONG

NOTE: ALL HOSES ARE 1/2" Ø

PIPE LINES:

- #9 - (2) 1/2" PIPE, 54" LONG
- #10 - (2) 1/2" PIPE, 86" LONG

NOTE: 1" N.C. THRD. ON BOTH ENDS OF #9 & #10

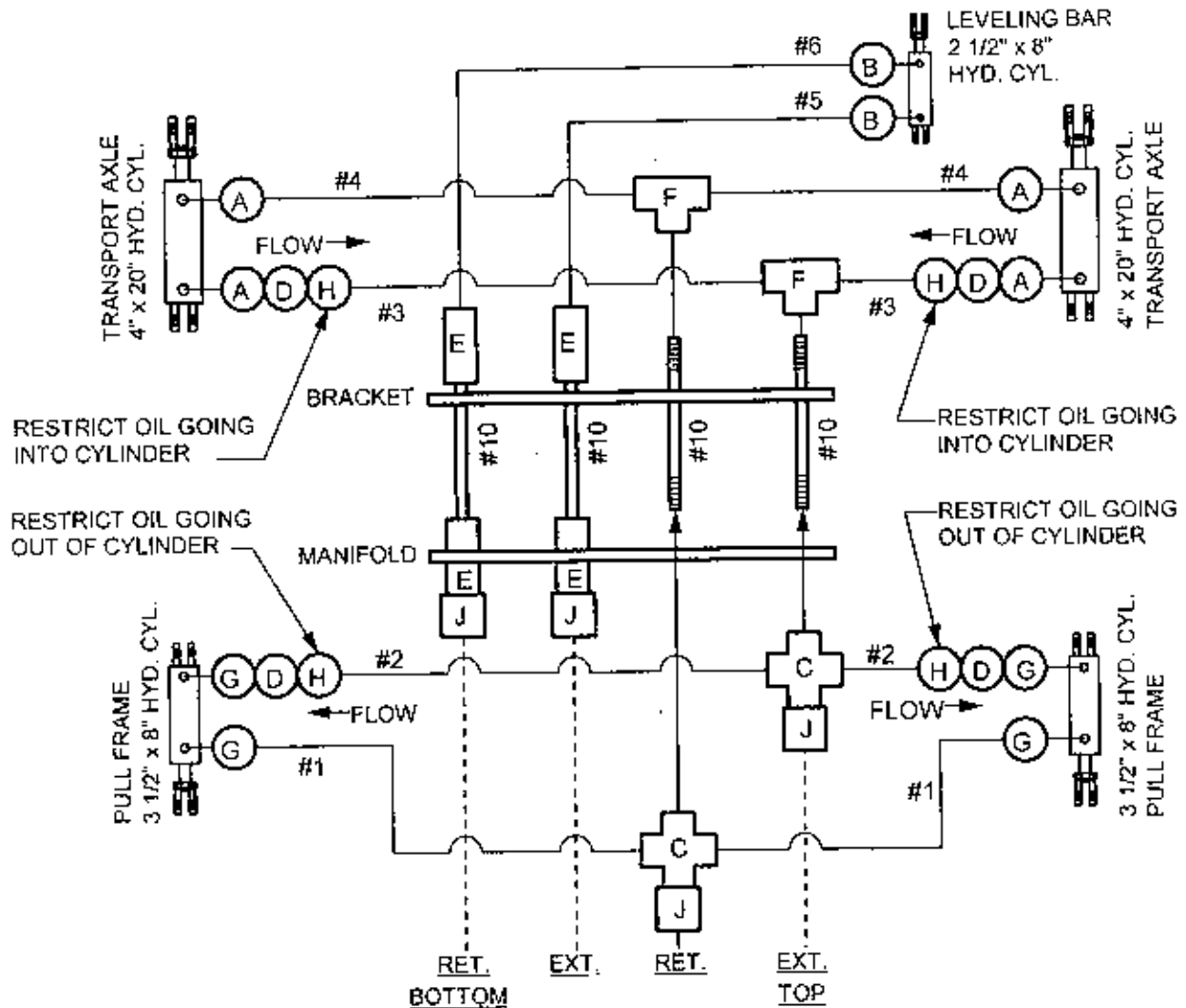

FRONT OF UNIT

FITTINGS:

- A. (4) 8MB-8FPX90°
- B. (2) 8MB-8FP ADAPTER
- C. (2) 8FP CROSS FITTING
- D. (4) 8MP NIPPLES
- E. (4) 8FP COUPLINGS
- F. (2) 8FP TEE FITTINGS
- G. (4) 8MP-8FPX90°
- H. (4) PM-R-13 RESTRICTORS
W/ 3/32" Ø HOLE
- J. (4) 8MP PLUGS

NOTE: ALL FITTINGS 3000# CAP.

HYD. CYLINDERS

- (1) 2 1/2" x 8" TIE ROD CYL.
- (2) 3 1/2" x 8" WELDED CYL.
- (2) 4" x 20" TIE ROD CYL.

HOSES:

- #1 - (2) 8MP-8MP 34" LONG
- #2 - (2) 8MP-8MP 30" LONG
- #3 - (2) 8MP-8MP 65" LONG
- #4 - (2) 8MP-8MP 56" LONG
- #5 - (1) 8MP-8MPX 50" LONG
- #6 - (1) 8MP-8MPX 55" LONG

NOTE: ALL HOSES ARE 1/2" Ø

PIPE LINES:

- #10 - (4) 1/2" PIPE, 86" LONG

NOTE: 1" N.C. THRD. ON BOTH ENDS OF #10



T. G. SCHMEISER CO., INC. **4-BAR TILL AN' BEDDER HYD. DIA. 18'-20' UNITS**

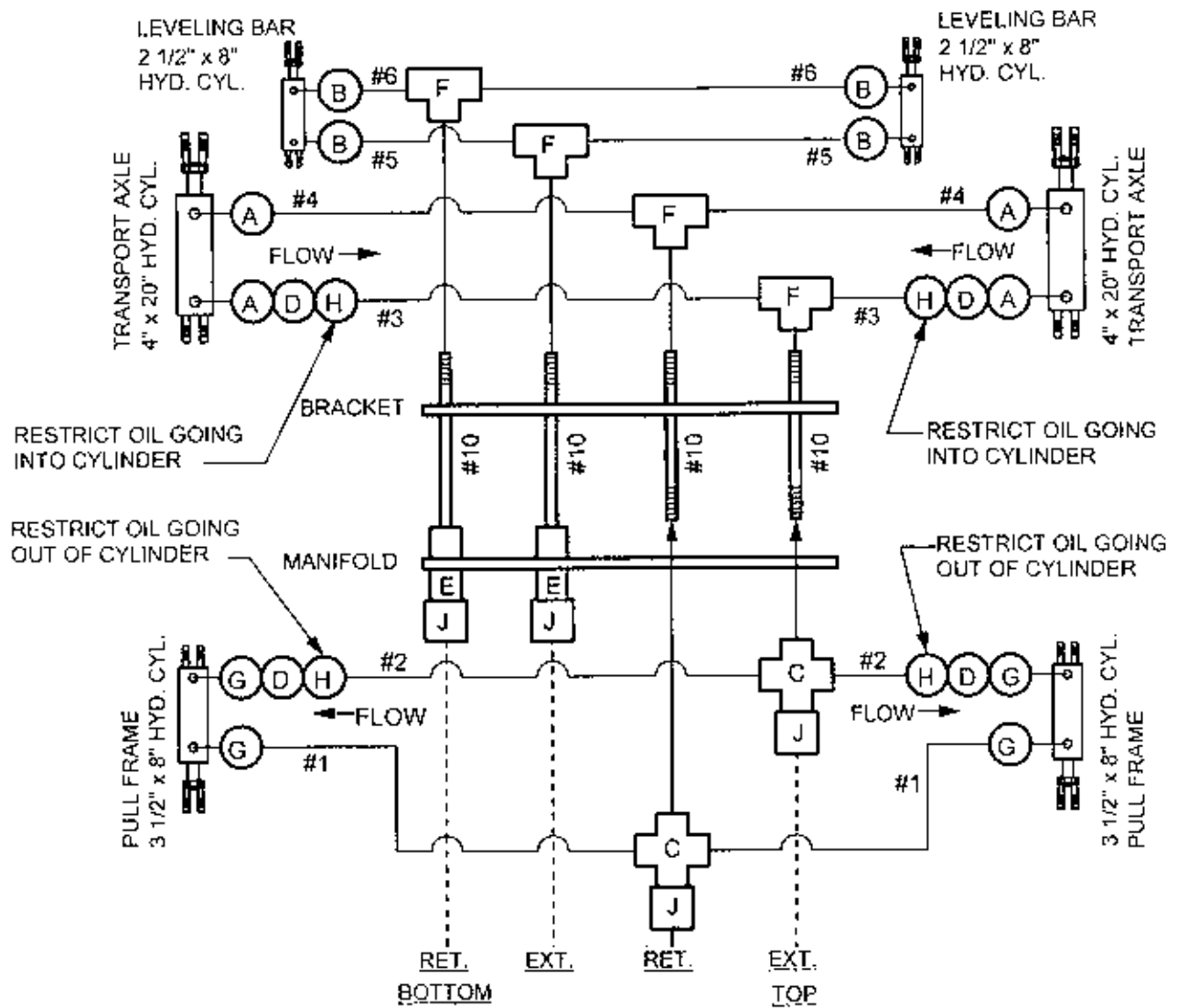

FRONT OF UNIT

PIPE LINES:

#10 - (4) 1/2" PIPE, 86" LONG

NOTE: 1" N.C. THRD. ON BOTH ENDS OF #10

HYD. CYLINDERS

- (2) 2 1/2" x 8" TIE ROD CYLINDERS
- (2) 3 1/2" x 8" WELDED CYLINDERS
- (2) 4" x 20" TIE ROD CYLINDERS

FITTINGS:

- A. (4) 8MB-8FPX90°
- B. (4) 8MB-8FP STGHT LINK
- C. (2) 8FP CROSS FITTING
- D. (4) 8MP NIPPLES
- E. (2) 8FP COUPLINGS
- F. (4) 8FP TEE FITTINGS
- G. (4) 8MP-8FPX90°
- H. (4) PM-R-13 RESTRICTORS
W/ 3/32" Ø HOLE
- J. (4) 8MP PLUGS

NOTE: ALL FITTINGS 3000# CAP.

T.G. SCHMEISER CO., INC.

Limited Warranty Statement

T. G. Schmeiser Co., Inc. warrants each new Schmeiser product to be free from defects in material and workmanship. This warranty is applicable only for the normal service life expectancy of the product or components, not to exceed twelve (12) consecutive months from the date of delivery of the new Schmeiser product to the original purchaser.

Genuine T. G. Schmeiser Co., Inc. replacement parts and components will be warranted for 365 days from date of purchase, or the remainder of the original equipment warranty period, whichever is longer.

Under no circumstances will it cover any merchandise or components thereof, which, in the opinion of the company, has been subjected to misuse, unauthorized modifications, alteration, an accident or if repairs have been made with parts other than those obtainable through T. G. Schmeiser Co., Inc.

The Company in no way warrants engines, batteries, cylinders, tires or other trade accessories since these items are warranted separately by their respective manufacturer. Expendable components such as points, shanks, blades, rings, bearings, teeth, and the like are excluded from this warranty.

Our obligation under this warranty shall be limited to repairing or replacing, free of charge to the original purchaser, any part that, in our judgment, shall show evidence of such defect, provided further that such part shall be returned within thirty (30) days from date of failure to T. G. Schmeiser Co., Inc., routed through the dealer and distributor from whom the purchase was made, transportation charges prepaid.

This warranty shall not be interpreted to render T. G. Schmeiser Co., Inc. liable for injury or damages of any kind or nature to person or property. This warranty does not extend to the loss of crops, loss because of delay in harvesting, or any expense or loss incurred for labor, substitute machinery, rental or for any other reason.

Except as set forth above, T. G. Schmeiser Co., Inc. shall have no obligation or liability of any kind on account of any of its equipment and shall not be liable for special or consequential damages. T. G. Schmeiser Co., Inc. makes no other warranty, expressed or implied, and, specifically, T. G. Schmeiser Co., Inc. disclaims any implied warranty or merchantability or fitness for a particular purpose. Some states or provinces do not permit limitations or exclusions of implied warranties or incidental or consequential damages, so the limitations or exclusion in this warranty may not apply.

This warranty is subject to any existing conditions of supply, which may directly affect our ability to obtain materials or manufacture replacement parts.

T. G. Schmeiser Co., Inc. reserves the right to make improvements in design or changes in specifications at any time, without incurring any obligation to owners of units previously sold.

No one is authorized to alter, modify or enlarge this warranty nor the exclusion, limitations and reservations.

